

Spectroscopy

And Its Applications



Project Submitted by:

Ankit Bahuguna

XII-A

Student Roll No.

CONTENTS

1. Introduction
2. Physical Quantities measured
3. What Is Spectroscopy
4. Nature of light
5. The Electromagnetic Spectrum
6. General Types of Spectra
7. Continuous Spectra
8. Emission spectra
9. Absorption Spectra
10. Types of Spectroscopy
11. How Spectrometer work?
12. Types of Spectroscopy
13. Examples of Spectroscopy in Astronomy
14. Probing the Formation of Stars in Colliding Galaxies in the universe.
15. Uncovering the mystery of quasar
16. Spectroscopy in Astronomy camp
17. Stars like our own Sun
18. Bibliography

1. Introduction

Spectroscopy

(PIC: Extremely high resolution spectrum of the Sun showing thousands of elemental absorption lines ([Fraunhofer lines](#)))

Spectroscopy is the study of matter and its properties by investigating light, sound, or particles that are emitted, absorbed or scattered by the matter under investigation.

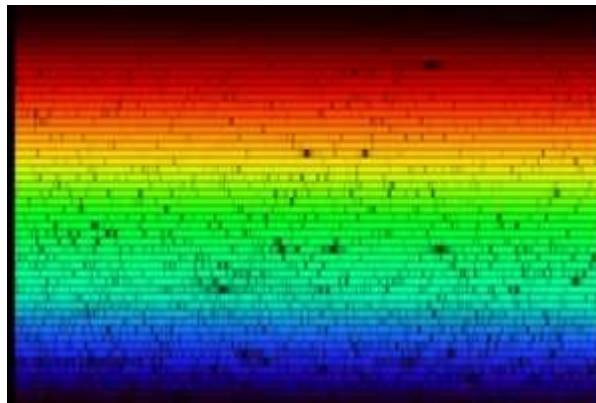

Spectroscopy may also be defined as the study of the interaction between **light** and **matter**. Historically, spectroscopy referred to a branch of science in which *visible light* was used for theoretical studies on the structure of matter and for qualitative and quantitative analyses. Recently, however, the definition has broadened as new techniques have been developed that utilize not only visible light, but many other forms of **electromagnetic** and non-electromagnetic radiation: **microwaves**, **radiowaves**, **x-rays**, **electrons**, **phonons** (**sound waves**) and others. **Impedance spectroscopy** is a study of **frequency response** in alternating current.

Spectroscopy is often used in **physical** and **analytical chemistry** for the identification of substances through the spectrum emitted from them or absorbed in them. A device for recording a spectrum is a **spectrometer**. Spectroscopy can be classified according to the physical quantity which is measured or calculated or the measurement process.

Spectroscopy is also heavily used in **astronomy** and **remote sensing**. Most large **telescopes** have spectrographs, which are used either to measure the chemical composition and physical properties of astronomical objects or to measure their velocities from the **Doppler shift** of spectral lines.

Physical Quantity Measured

The type of spectroscopy depends on the physical quantity measured. Normally, the quantity that is measured is an amount or intensity of something.

- The intensity of emitted electromagnetic radiation and the amount of absorbed electromagnetic radiation are studied by electromagnetic spectroscopy (see also cross section).
- The amplitude of macroscopic vibrations is studied by acoustic spectroscopy and dynamic mechanical spectroscopy.

- Kinetic energy of particles is studied by electron energy loss spectroscopy and Auger electron spectroscopy (see also cross section).
- The mass-to-charge ratios of molecules and atoms are studied in mass spectrometry, sometimes called *mass spectroscopy*. Mass spectrometry is more of a measuring technique (metric) than an observation (scopic) technique but can produce a spectrum of masses, a mass spectrum, similar in appearance to other spectroscopy techniques.
- The number of molecules or atoms or quantum-mechanical states to which the frequency or energy parameter applies. In this case the spectrum is usually called cross section.

What is Spectroscopy?

Spectroscopy pertains to the dispersion of an object's light into its component colors (i.e. energies). By performing this dissection and analysis of an object's light, astronomers can infer the physical properties of that object (such as temperature, mass, luminosity and composition).

But before we hurtle headlong into the wild and woolly field of spectroscopy, we need to try to answer some seemingly simple questions, such as *what is light?* And *how does it behave?* These questions may seem simple to you, but they have presented some of the most difficult conceptual challenges in the long history of physics. It has only been in this century, with the creation of quantum mechanics that we have gained a quantitative understanding of how light and atoms work. You see, the questions we pose are not always easy, but to understand and solve them will unlock a new way of looking at our Universe.

The Nature of Light

To understand the processes in astronomy that generate light, we must realize first that *light acts like a wave*. Light has particle-like properties too, so it's actually quite a twisted beast (which is why it took so many years to figure out). But right now, let's just explore light as a wave.

Picture yourself wading around on an ocean beach for a moment, and watch the many water waves sweeping past you. Waves are disturbances, ripples on the water, and they possess a certain height (*amplitude*), with a certain number of waves rushing past you every minute (the *frequency*) and all moving at a characteristic speed across the water (the *wave speed*). Notice the distance between successive waves? That's called the *wavelength*.

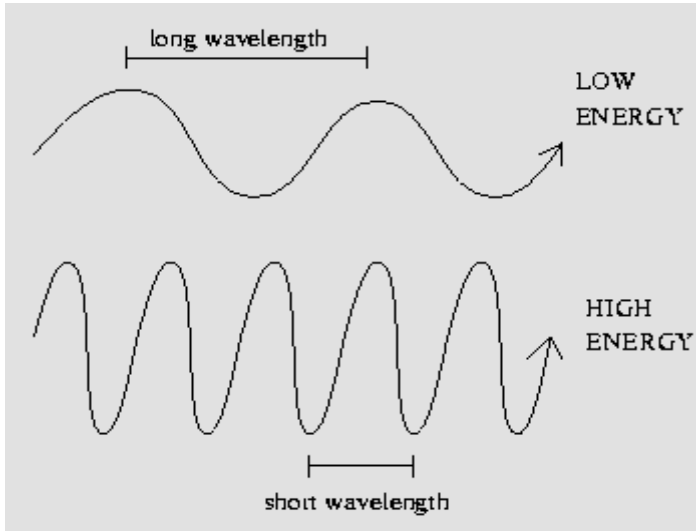

Keeping this analogy in mind, let's leave the ocean beach for a while and think about light like a wave. The *wave speed* of a light wave is simply the speed of light, and *different wavelengths of light manifest themselves as different colors!* The energy of a light wave is inversely-proportional to its wavelength; in other words, *low-energy waves have long wavelengths, and high-energy light waves have short wavelengths.*

The Electromagnetic Spectrum

Physicists classify light waves by their energies (wavelengths). Labeled in increasing energy, we might draw the entire *electromagnetic* spectrum as shown in the figure below:

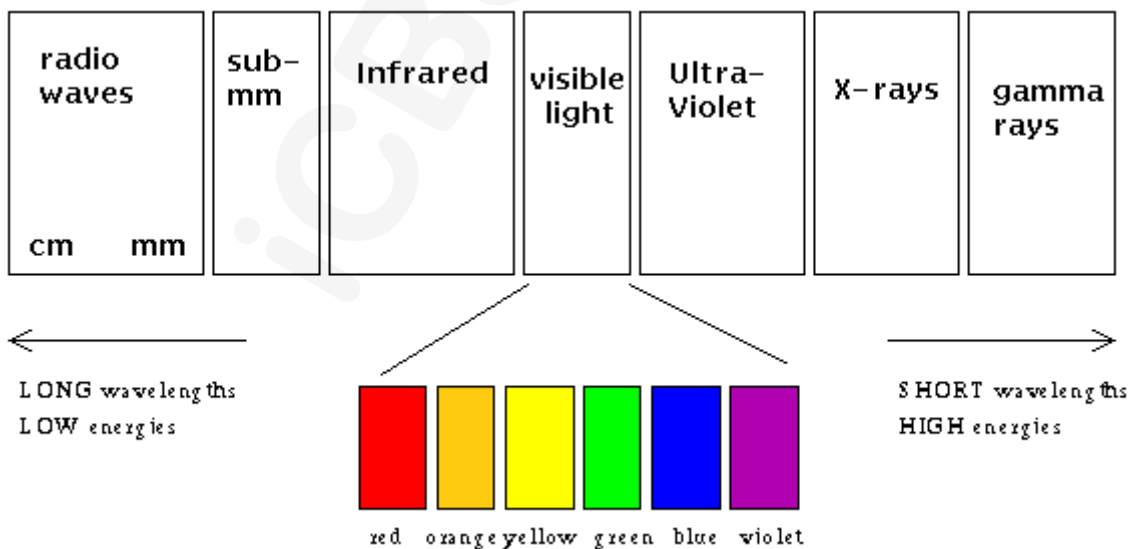

(The Electromagnetic Spectrum. Notice how small the visible region of the spectrum is, compared to the entire range of wavelengths.)

Notice that radio, TV, and microwave signals are all light waves, they simply lie at wavelengths (energies) that your eye doesn't respond to. On the other end of the scale, beware the high energy UV, x-ray, and gamma-ray photons! Each one carries a lot of energy compared to their visible- and radio-wave brethren. They're the reasons you should wear sunblock, for example.

When we look at the Universe in a different "light", i.e. at "non-visible" wavelengths, we probe different kinds of physical conditions -- and we can see new kinds of objects! For example, high-energy gamma-ray and X-ray telescopes tend to see the most energetic dynamos in the cosmos, such as active galaxies, the remnants from massive dying stars, accretion of matter around black holes, and so forth. Visible light telescopes best probe light produced by stars. Longer-wavelength telescopes best probe dark, cool, obscured structures in the Universe: dusty star-forming regions, dark cold molecular clouds, the primordial radiation emitted by the formation of the Universe shortly after the Big Bang. *Only through studying astronomical objects at many different wavelengths are astronomers able to piece together a coherent, comprehensive picture of how the Universe works!*

General Types of Spectra

Typically one can observe two distinctive classes of spectra: *continuous* and *discrete*. For a continuous spectrum, the light is composed of a wide, continuous range of colors (energies). With discrete spectra, one sees only bright or dark lines at very distinct and sharply-defined colors (energies). As we'll discover shortly, discrete spectra with bright lines are called *emission* spectra, those with dark lines are termed *absorption* spectra.

Continuous Spectra

Continuous spectra arise from dense gases or solid objects which radiate their heat away through the production of light. Such objects emit light over a broad range of wavelengths, thus the apparent spectrum seems smooth and continuous. Stars emit light in a *predominantly* (but not completely!) continuous spectrum. Other examples of such objects are incandescent light bulbs, electric cooking stove burners, flames, cooling fire embers and... **you**. Yes, you, right this minute, are emitting a continuous spectrum -- but the light waves you're emitting are not visible -- they lie at infrared wavelengths (i.e. lower energies, and longer wavelengths than even red light). If you had infrared-sensitive eyes, you could *see people by the continuous radiation they emit!*

Discrete Spectra

Discrete spectra are the observable result of the physics of atoms. There are two types of discrete spectra, **emission** (bright line spectra) and **absorption** (dark line spectra). Let's try to understand where these two types of discrete spectra.

Emission Line Spectra

Unlike a continuous spectrum source, which can have *any* energy it wants (all you have to do is change the temperature), the electron clouds surrounding the nuclei of atoms can have only very specific energies dictated by quantum mechanics. Each element on the periodic table has its own set of possible energy levels, and with few exceptions the levels are distinct and identifiable. Atoms will also tend to settle to the lowest energy level (in spectroscopist's lingo, this is called the *ground state*). This means that an excited atom in a higher energy level must 'dump' some energy. The way an atom 'dumps' that energy is by emitting a wave of light with that *exact* energy.

In the diagram below, a hydrogen atom drops from the 2nd energy level to the 1st, giving off a wave of light *with an energy equal to the difference of energy between levels 2 and 1*. This energy corresponds to a specific color, or wavelength of light - - and thus we see a bright line at that *exact* wavelength! ...an *emission spectrum* is born, as shown below:

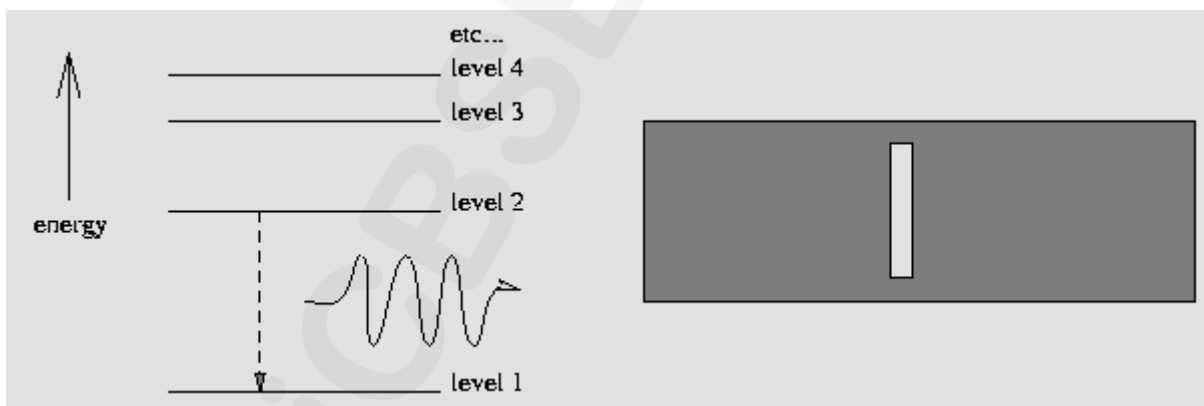

An excited Hydrogen atom relaxes from level 2 to level 1, yielding a photon. This results in a bright *emission* line.

Tiny changes of energy in an atom generate photons with small energies and long wavelengths, such as radio waves! Similarly, large changes of energy in an atom will mean that high-energy, short-wavelength photons (UV, x-ray, gamma-rays) are emitted.

Absorption Line Spectra

On the other hand, what would happen if we tried to reverse this process? That is, what would happen if we fired this special photon back into a ground state

atom? That's right, the atom could absorb that 'specially-energetic' photon and would become excited, jumping from the ground state to a higher energy level. If a star with a 'continuous' spectrum is shining upon an atom, the wavelengths corresponding to possible energy transitions within that atom will be absorbed and therefore an observer will not see them. In this way, a *dark-line absorption spectrum* is born, as shown below:

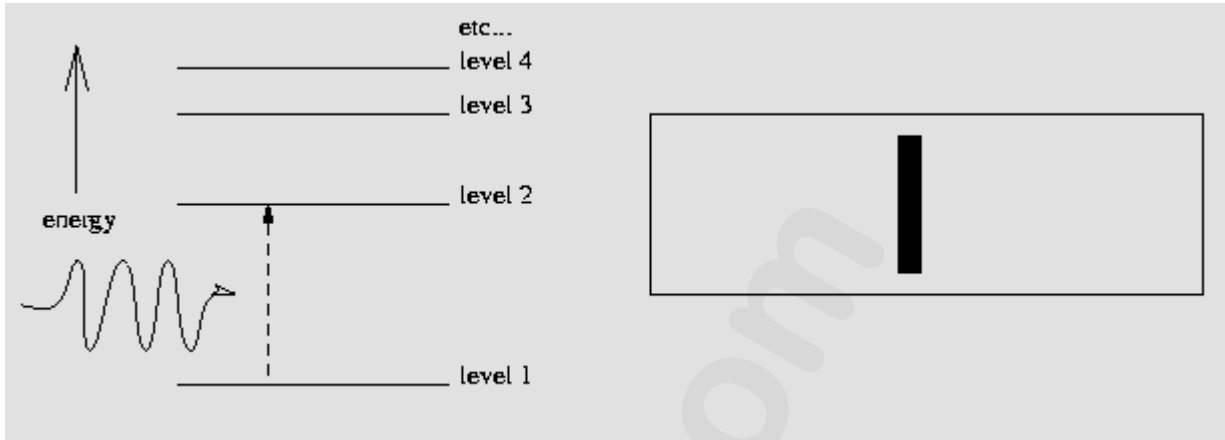

How does a spectrometer work?

Many people know how a telescope works, but relatively few have much experience with the innards of a spectrometer. So let's take apart the Astronomy Camp spectrometer to see how it works! Keep in mind that there are as many optical designs for spectrometers as there are optical designs for telescopes, and that this is but one example. Nevertheless, it points out the salient features of most optical spectrometers.

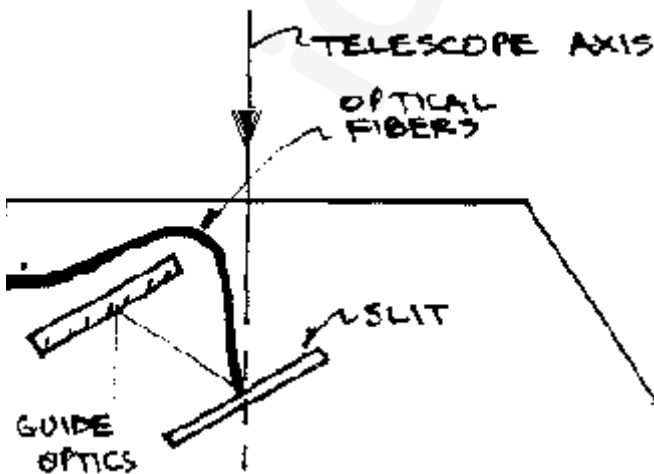

It all starts with the telescope light beam entering the spectrometer. The focal point of the telescope beam is brought to the *slit* of the spectrometer. **This slit is what is ultimately imaged on the detector.** In the case of the Camp spectrometer, the slit is arranged at an angle and the slit surroundings are silvered so that the portion of the telescope beam not passing through the slit can be routed instead to an eyepiece for

easy telescope guiding.

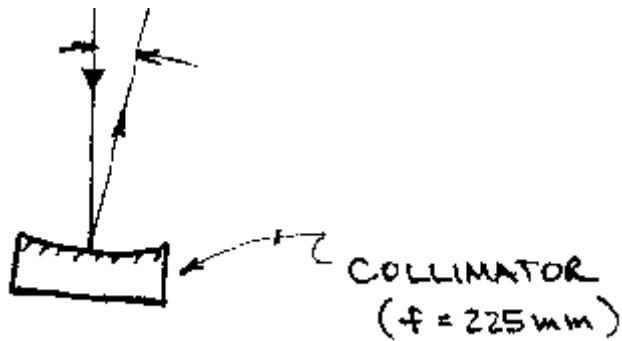

The light passing through the slit then is reflected off a *collimating mirror*, which parallelizes the beam of light, before sending it off...



... to the *diffraction grating*! This optical element disperses the parallel beams of light into their component colors/wavelengths/energies. Each different wavelength comes off of the grating at a slightly different angle. So now, we have an image of the slit that is spread out like a rainbow by color.

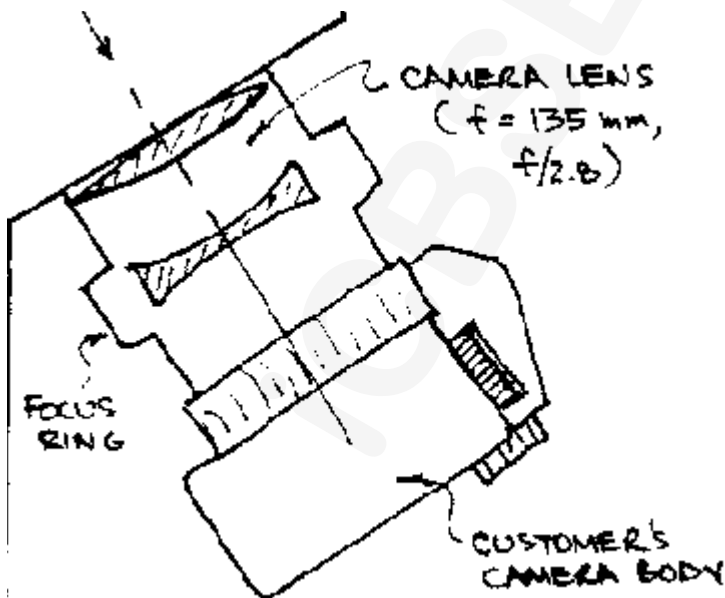

This new color-dispersed beam of light is then focused and imaged on the detector by the *camera lens*. A 35 mm camera is the detector in this diagram, but at Camp, we typically use an eyepiece or a CCD array.

So, now let's put all of this together to make a spectrometer!

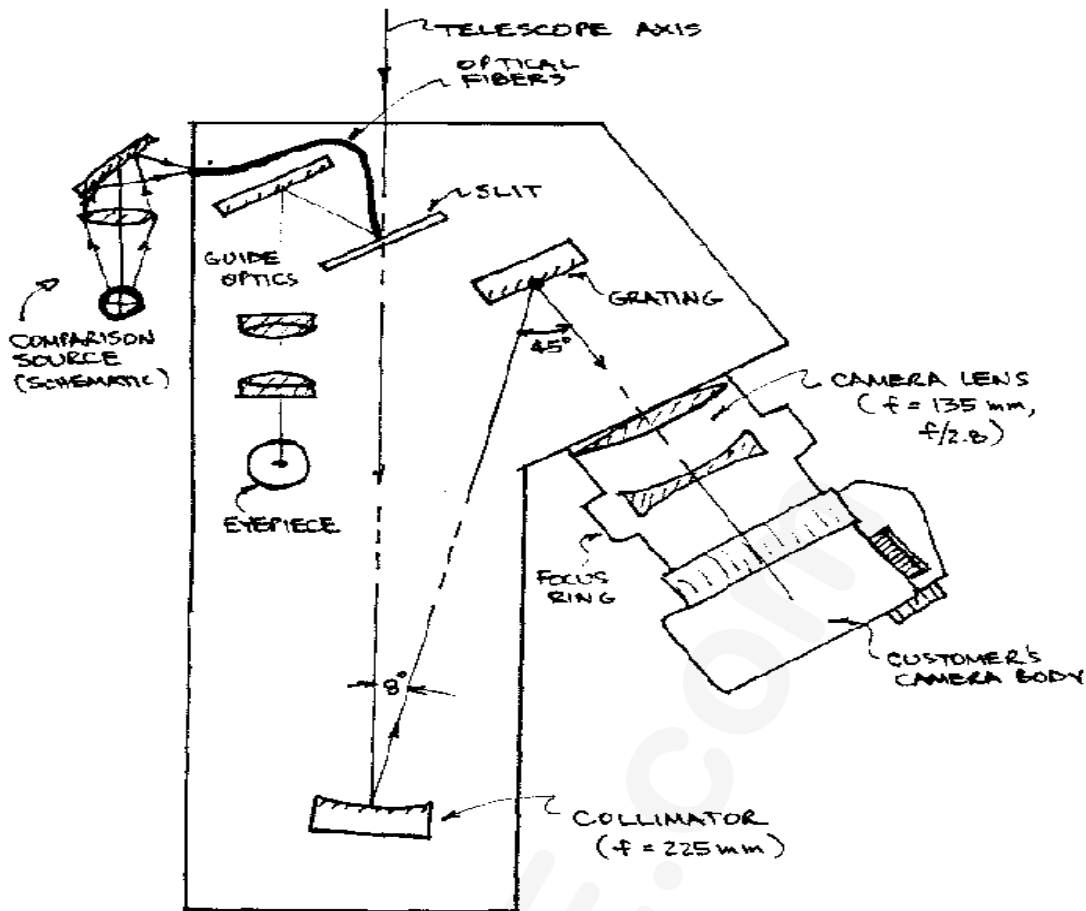

There is something interesting to note here -- in spectroscopy, we are not looking at ALL of the light from an object, just a certain "band" of wavelengths or colors. Furthermore, even that band is dispersed ("smeared out") over the entire detector. This means that the effective brightness, or *surface brightness* of an object on the detector is **much** lower than when simply taking images of an object. This means that it takes a bigger telescope and/or more integration time to get a good spectrum of a given object than an image.

The broader you disperse the light and the narrower you make the slit, the better your spectral resolution; you can see finer and more subtle features in the spectrum. However, there is a stiff price to pay: the emergent spectrum becomes much dimmer and more diffuse. High resolution spectroscopy therefore requires large telescopes and fairly bright objects. For very faint objects, some spectral resolution often must be compromised to even SEE the object.

TYPES OF SPECTROSCOPY

In general there are three main types of spectroscopy. They are as listed below:

1. Absorption Spectroscopy
2. Emission Spectroscopy
3. Scattering Spectroscopy

Absorption spectroscopy uses the range of electromagnetic spectra in which a substance absorbs. In atomic absorption spectroscopy, the sample is atomized and then light of a particular frequency is passed through the vapour. After calibration, the amount of absorption can be related to the concentrations of various metal ions through the Beer-Lambert law. The method can be automated and is widely used to measure concentrations of ions such as sodium and calcium in blood. Other types of spectroscopy may not require sample atomization. For example, ultraviolet/visible (UV/ Vis) absorption spectroscopy is most often performed on liquid samples to detect molecular content and infrared (IR) spectroscopy is most often performed on liquid, semi-liquid (paste or grease), dried, or solid samples to determine molecular information, including structural information.

Emission spectroscopy uses the range of electromagnetic spectra in which a substance radiates. The substance first absorbs energy and then radiates this energy as light. This energy can be from a variety of sources, including collision (either due to high temperatures or otherwise), and chemical reactions.

Scattering spectroscopy measures certain physical properties by measuring the amount of light that a substance scatters at certain wavelengths, incident angles, and polarization angles. Scattering spectroscopy differs from emission spectroscopy due to the fact that the scattering process is much faster than the absorption/emission process. One of the most useful applications of light scattering spectroscopy is Raman spectroscopy.

Development of New-Type NMR Spectrometer with Ultra High Sensitivity

~ Key issues and concept ~

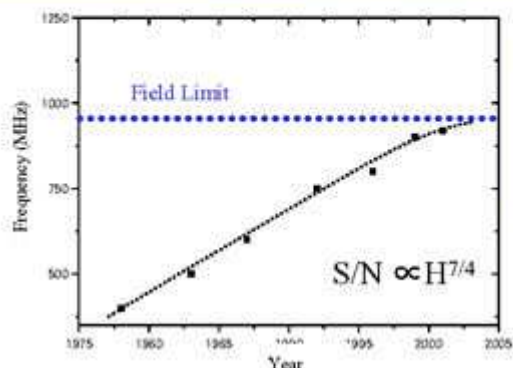

- ① Open space enabling new applications
- ② Superconducting solenoid pick-up coil with high sensitivity
- ③ Split-pair superconducting Magnet

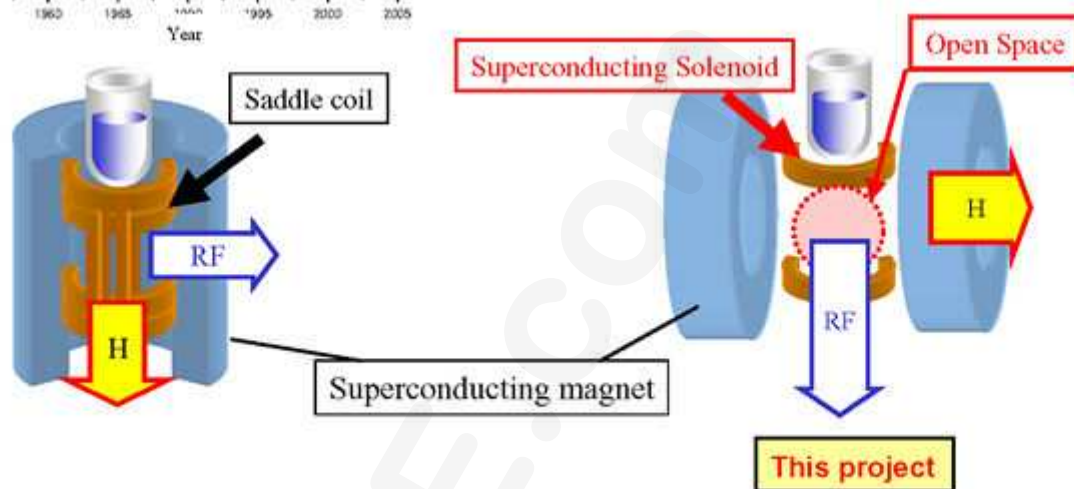

NMR SPECTROSCOPY

Nuclear Magnetic Resonance spectroscopy is a powerful and theoretically complex analytical tool. On this page, we will cover the basic theory behind the technique. It is important to remember that, with NMR, we are performing experiments on the **nuclei** of atoms, not the electrons. The chemical environment of specific nuclei is deduced from information obtained about the nuclei.

Examples of Spectroscopy in Astronomy

Spectroscopy is a powerful tool in astronomy -- from it, we can often get information about the temperature, density, composition, and important physical processes of an astronomical object. This information can help us answer the questions:

- *What is it?*
- *What is it like?*
- *What is it made out of?*
- *How did it get there? What will happen to it?*
- *Does it give us clues as to how WE got here?*

A few examples of astronomical spectra are highlighted here. Some cool [Astronomy Camp spectra](#) also live in these pages.

Molecular Spectroscopy and Comets

Comets consist of almost pristine material from the early formation of our solar system, unprocessed by harsh solar sunlight. Studying the chemistry of these "dirty snowballs" gives us a clue as to the composition and nature of our solar system in its infancy and constrains theories of how life may have formed on Earth.

A link to radio-wavelength [spectroscopy of comets may be found here](#).

Probing the Formation of Stars in Colliding Galaxies

Billions of years ago, when our galaxy took form, it is thought that there must have been an epoch of rapid star-forming activity that has since subsided. We can get clues to how this may have looked by observing galaxies currently exhibiting violent, extreme star-formation. Such "starburst" galaxies are studied best in the infrared and at radio wavelengths, since star-forming galaxies often harbor so much dust and gas that visible light cannot penetrate to the centers where the majority of the star formation is taking place. Below is an infrared (2.0 - 2.5 microns wavelength, or 20,000 - 25,000 Angstroms) spectrum of two such starburst galaxies. Most of the features you see are from molecular hydrogen, H_2 , the stuff from which stars are made! These molecular hydrogen emission lines tell us that the molecular gas we see is very warm; in the top galaxy, the gas is excited by shock-heated gas. The bottom galaxy has molecular hydrogen excited by ultraviolet light emitted from recently-formed young, hot stars.

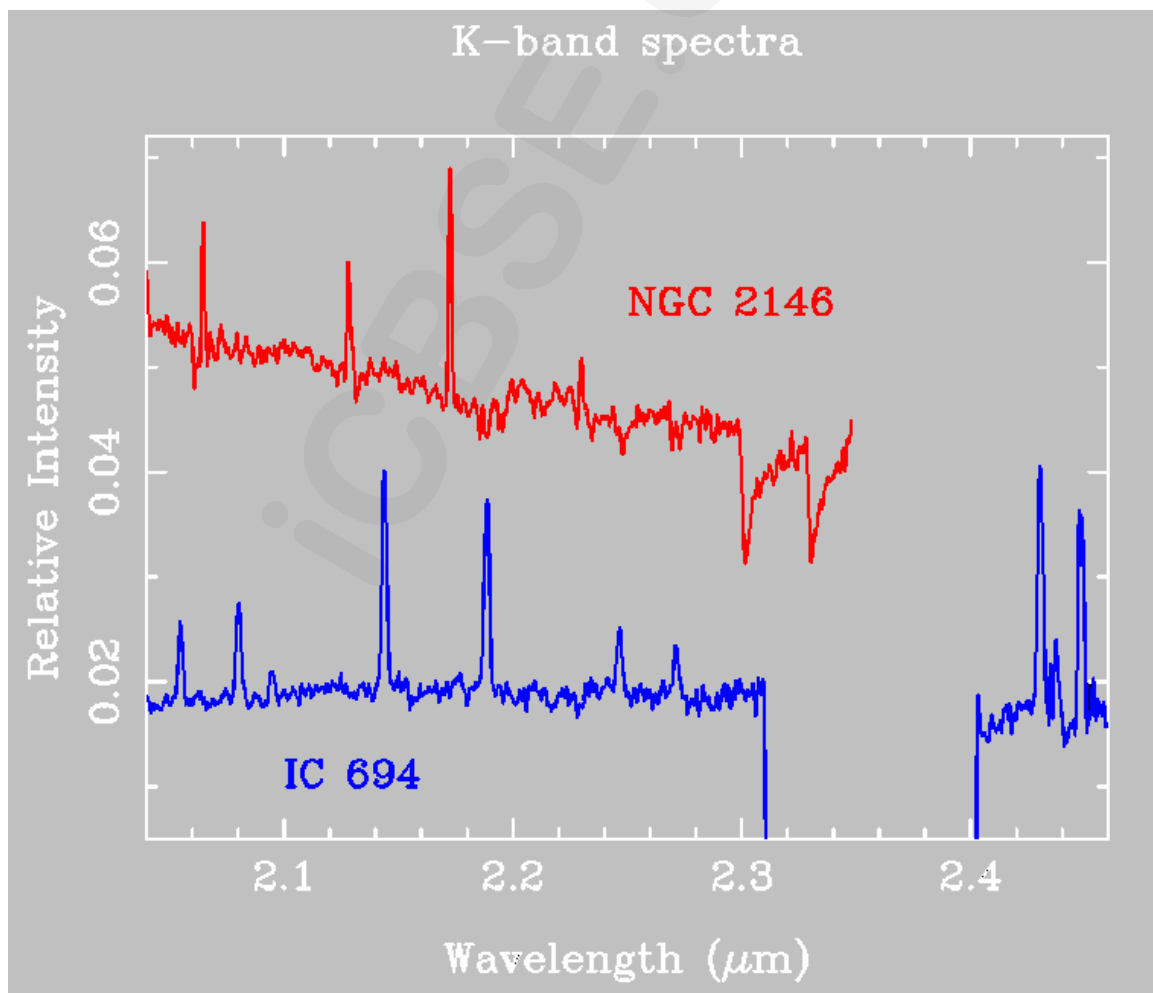

Uncovering the mystery of Quasars

The distant nature of quasars were discovered in the early 1960's, when spectral lines were noted to be substantially-shifted *redder* than they should normally be. This *redshift* can be attributed to the recession (speeding away) of quasars from us. In the standard Big Bang model of cosmology (the faster it's speeding away from you, the more distant it is), this rapid motion implies that quasars are the most distant objects known. Below is a typical spectrum of a quasar. The wavelength scale has been rescaled to the "appropriate" rest wavelengths for the spectral lines. The most noticeable feature is the broad emission line at 1216 Angstroms due to hydrogen atoms making the transition from the first excited state to the ground state. Although 1216 Angstroms lies deep in the ultraviolet, where the Earth's atmosphere is opaque, many quasars are receding from us so fast, this line is redshifted into the visible part of the spectrum (4000-7000 Angstroms).

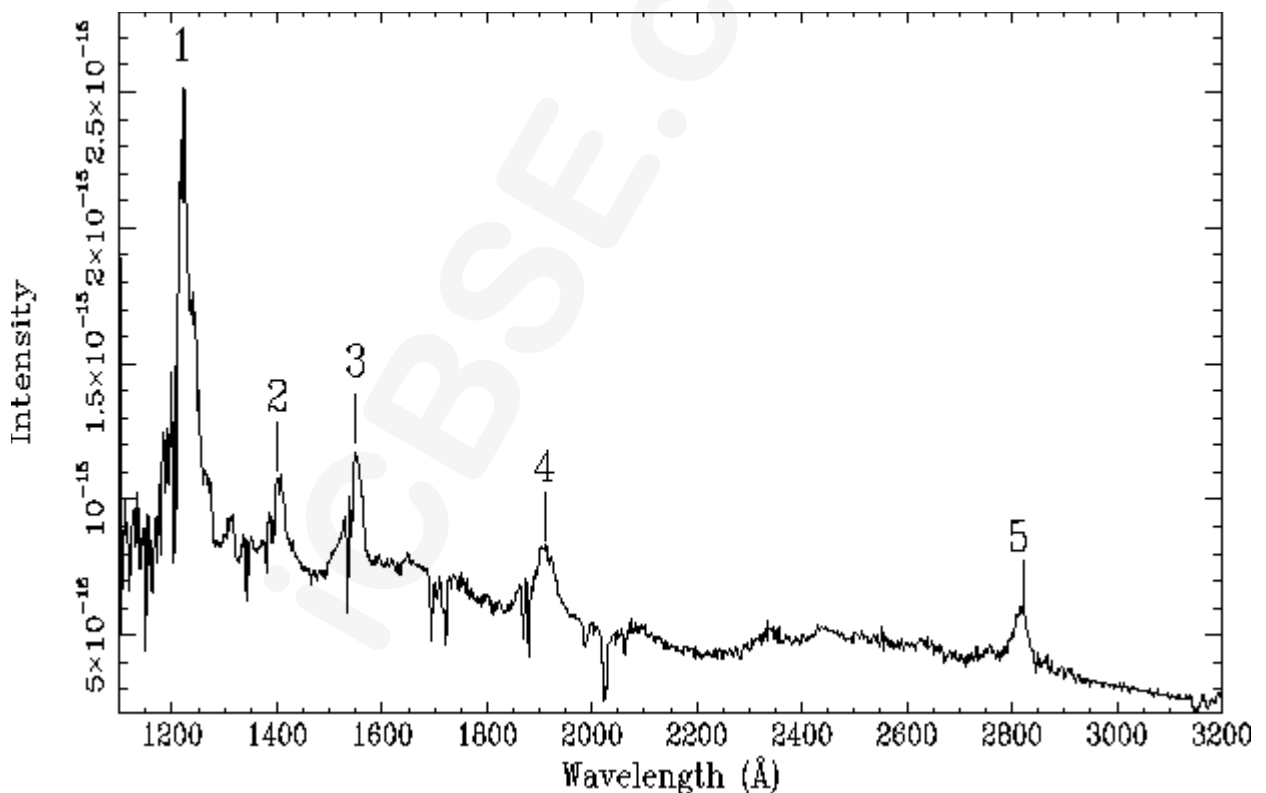

Spectroscopy at Astronomy Camp!

Spectroscopy at Astronomy Camp is done with a [spectrograph](#) from Optomechanics Research Inc, coupled with the Mount Lemmon 40" or 60" telescopes and the Camp's SBIG ST6 CCD detector array. With relatively short exposure times, good quality spectra can be taken of most catalogued stars and high surface-brightness deep-sky objects. A few examples of Astronomy Campers' handiwork are shown below.

Planetary Nebulae, Or 'Why Light Pollution Filters Work!'

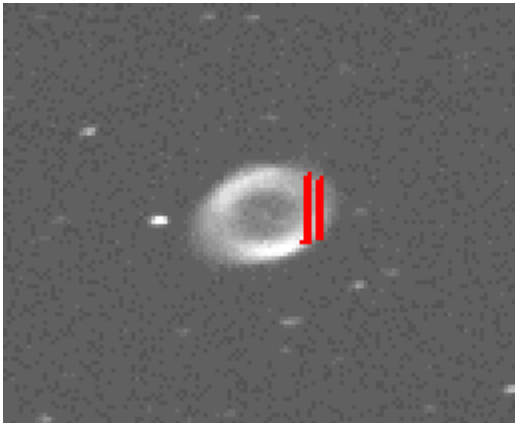

Here's an image of M57 (a.k.a. the Ring Nebula), with a crude representation of the spectrometer slit superimposed. This image is a 180 second exposure using the Camp's ST6 CCD on a 10" Meade Schmidt-Cassagrain telescope. Astronomy Camp's spectrograph was mounted on the Mount Lemmon 60" telescope with the same ST6 CCD. The slit length is about 8 arcminutes long and 1 arcsecond wide; the representation of the slit width in the diagram is exaggerated.

We combined four 5-minute exposures on the Ring Nebula using the 60" and the ST6 camera. We subtracted an appropriate 5 minute dark frame from each image and then combined the images using [IRAF](#). The resulting ST6 image follows: the dispersion (wavelength) axis is horizontal, and the spatial axis (along the Ring Nebula) is vertical. The central lines are M57, the upper and lower spikes are the calibration lamp spectra (Hg+He).

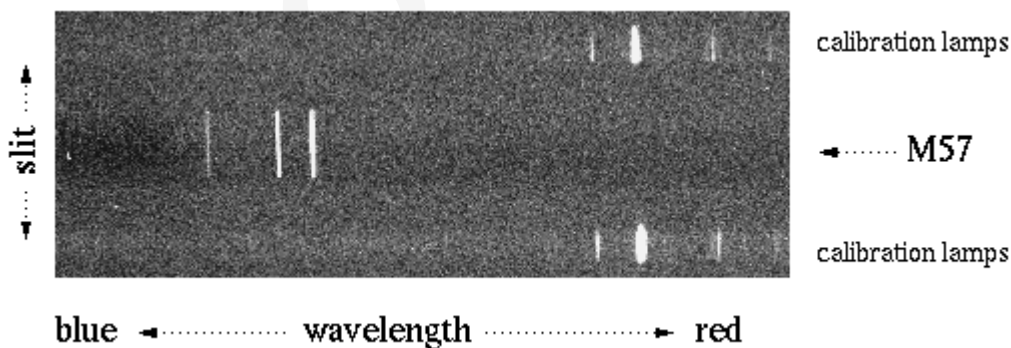

We make a 1-D spectrum from the 2-D image by summing over the aperture of the slit covering M57. Using the well-characterized wavelengths of the calibration lamps, we can use IRAF to register our spectrum to provide a nice

wavelength scale. Here's what our spectrum looks like once plotted as intensity versus wavelength.

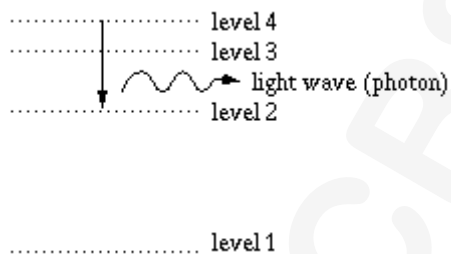
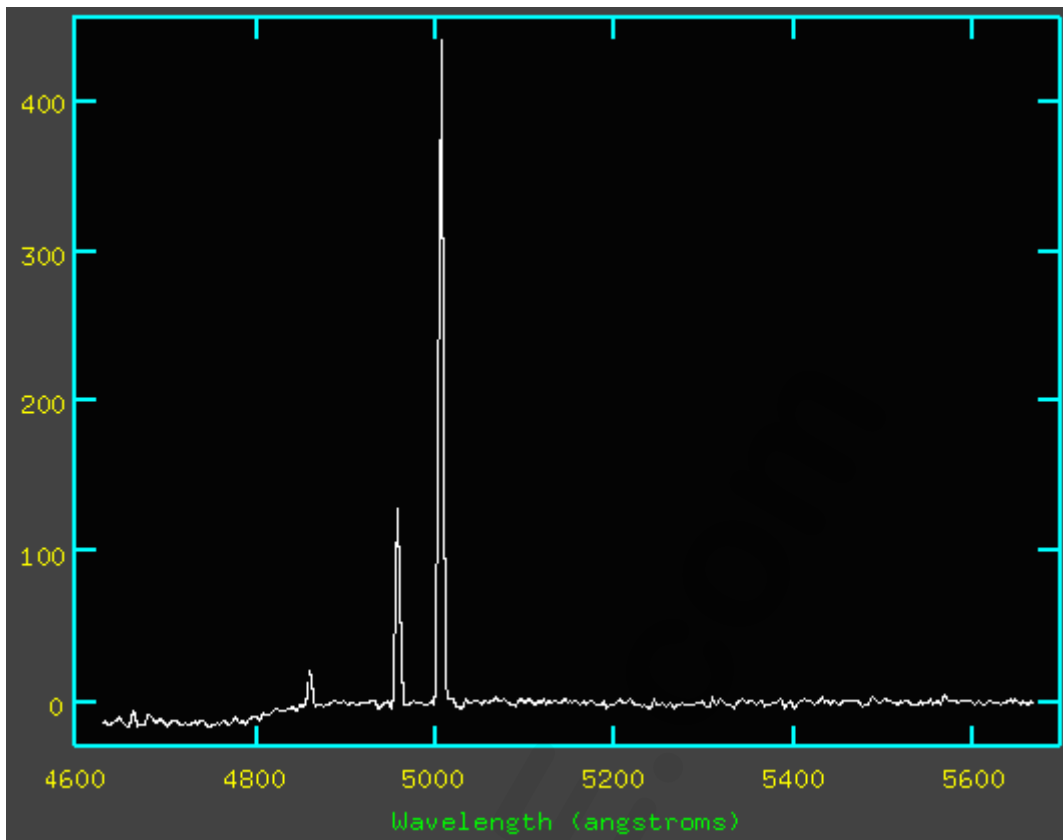

The emission line at 4861 Angstroms comes from hot, excited atomic hydrogen. Highly-excited hydrogen atoms in M57's gaseous shell, starting in energy level 4, may eventually de-excite to level 2, giving up the energy difference in waves of light at that particular energy (and... they have a wavelength of 4861 Angstroms!).

The brightest two lines at 4959 and 5007 Angstroms come from twice-ionized oxygen (labeled O^{++} , or $O\ III$ in spectroscopic notation). This means that two of oxygen's eight electrons have been ripped away. This is also a clue that conditions in this nebula must be harsh. In fact, these lines can only be excited to emit light in temperatures of several thousand Kelvins and rather thin densities of 1-100 atoms per cubic centimeter. There is no continuous spectrum here -- this points out the important fact that planetary nebulae are hot rarified gases -- you see a LINE spectrum. This also points out how astronomers can get valuable information about the physical conditions and important processes in distant astronomical objects.

This spectrum also demonstrates why you can use light-pollution filters (like those made by Lumicon or Orion) to get great contrast from reflection/emission nebulae! These filters pass light waves that lie at wavelengths covered by these three lines, but block light at all other wavelengths. For nebulae, this is very beneficial since they only emit visible light in this wavelength range. You can remove all that ugly skyglow and light pollution without reducing the brightness of the nebula you're looking for.

Would such a narrow-band filter be good for looking at stars or galaxies? Hmm?

Stellar Spectroscopy

A look at Sirius

Now, onto stellar spectroscopy. This 1/2 second exposure of Sirius is centered near 4000 Angstroms (blue, near-ultraviolet) and clearly shows a series of deep absorption lines. These lines are due to the hydrogen atom. Let's explore how.

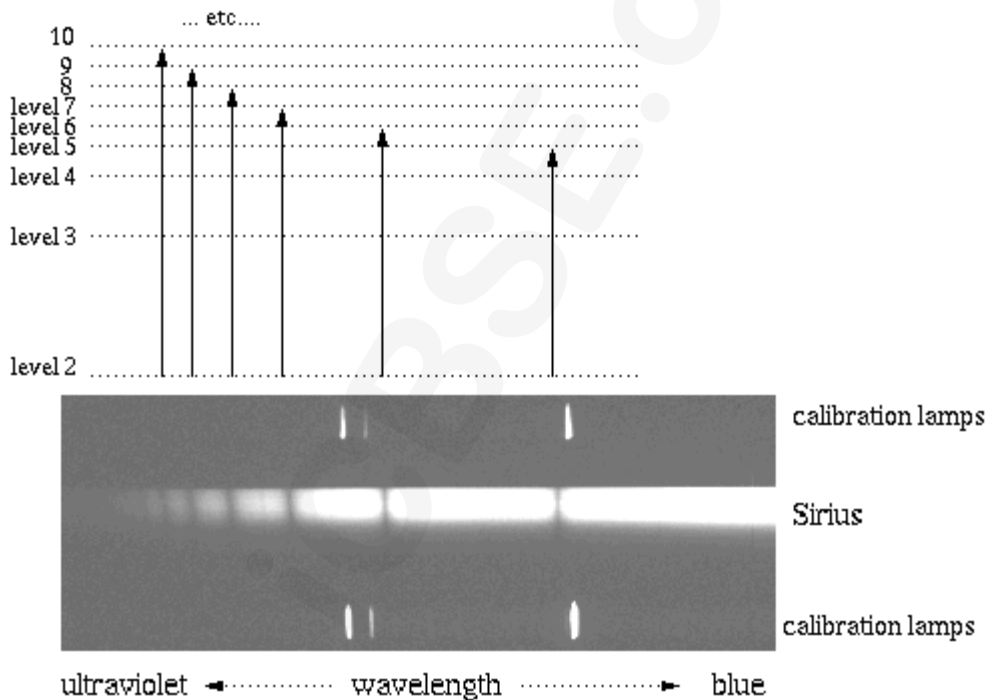

In the cooler outer "atmosphere" around Sirius, mildly excited hydrogen atoms in the 2nd energy level (the 1st excited state) are 'zapped' by photons (light waves) with just the right energy to send them to even higher excited states. In this figure, we match the dark absorption line that results from each transition upward in the hydrogen atom. Notice that the higher-energy transitions on the left result in higher energy absorption lines out in the ultraviolet. This series of lines, starting from level 2, is called the Balmer series after their discoverer.

Stars are classified by their temperatures, which can be determined by the star's spectral features. The hottest stars are termed O-stars, the next cooler are B stars, then A, F, G, K, and finally M-stars. Sirius is a relatively hot A-type star at about 10,000 degrees Kelvin. Such stars have the strongest hydrogen-features (simply due to temperature -- cooler stars can't 'zap' the hydrogen atoms as effectively, and hotter stars will destroy/ionize the hydrogen atoms that create the spectral lines!).

Molecules in Cool Stars!

On the other end of the scale -- here is Delta Virgo; a cool M3-type giant star at about 3,500 K and viewed at about 6000 Angstroms (in red light). Note a bright continuum at far left, which suddenly dims into a series of striations (bands).

These don't look like the sharp absorption lines of the hydrogen atom, do they? In fact, these bands are due to **MOLECULES** that can live in the atmospheres of these cool stars!

This particular molecule is TiO (titanium oxide). Molecules have a dizzying number of lines because they not only have the electron energy levels like atoms, but also have energy sublevels due to the rotation and vibration of the molecule!

At the modest resolution of our spectrometer, these hundreds of lines are blended into absorption bands like what we see here.

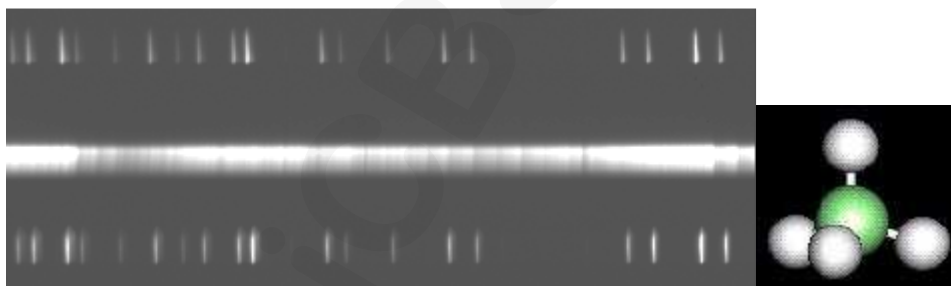

STARS LIKE OUR SUN

Somewhere between hotter A-type stars and cool M-class stars are stars like our sun, around 5500 degrees Kelvin. Here's Beta-Bootes, a G8 giant star (roughly what our sun will be when it begins dying in about 5 billion years). The first spectrum is at 5500 Angstroms (yellow light), just like the M-star spectrum above. Notice that molecules don't form here (it's too hot for molecules to readily form without being quickly destroyed), but there are still an awful lot of lines around. Most of these features are due to heavy elements -- things like carbon (in several ionization stages), iron, oxygen, magnesium, calcium etc.

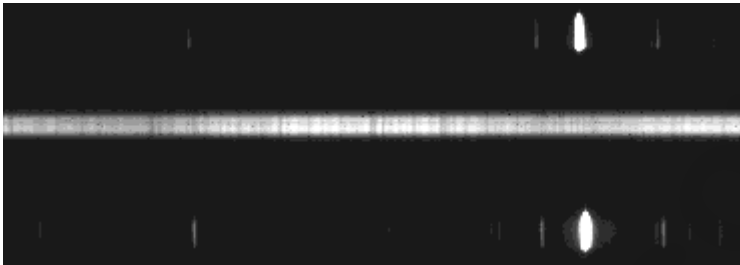

This is a spectrum of the same star, but now taken at 4000 Angstroms (deep blue-violet light). The deep absorption lines at left are due to the ion Calcium II (the difference between this and normal, neutral calcium is that one electron has been stripped off here). The small dip in the middle is due to a blend of metallic features and hydrogen. Notice that the hydrogen lines are very weak here -- nothing at all like Sirius (a hotter A-class star).

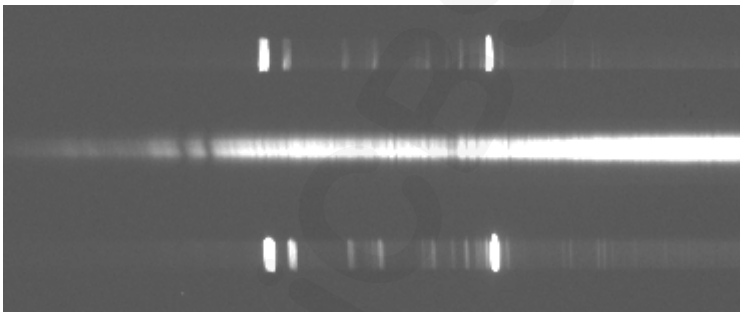

Bibliography

This project is made using the analytical data provided by the following reference books and websites:

1. Schaum's Outlines Organic Chemistry, Third Edition, Chapter Spectroscopy, Page number 230-244.
2. The Science of Spectroscopy - supported by NASA, includes Open Spectrum, a Wiki-based learning tool.
3. Wikipedia (Encyclopedia)
4. Professors Lectures University of Arizona (Semester II)

WebLinks:

- www.Askjeeves.com
- www.icbse.com
- http://loke.as.arizona.edu/~ckulesa/camp/camp_spectroscopy.html
- http://www.nanonet.go.jp/english/info/nanoproject/kitaguchi_2.jpg
- www.loke.as.arizona.edu